



# Model FT20A Metallic

## AIR OPERATED DOUBLE DIAPHRAGM PUMPS

### Specifications

Suction & Discharge Size:	2" x 2"
Porting Location:	Center
Connection Types:	FNPT, BSPT
Air Inlet x Air Exhaust Size:	3/4" FNPT x 3/4" FNPT

### Capabilities

Maximum Flow Rate:	156 gpm (590 lpm)
Maximum Air Supply Pressure:	120 psi (8.3 bar)
Displacement Per Stroke:	0.31 gal (1.2 lit)
Minimum Air Inlet Pressure:	10 psig (0.7 bar)
Maximum Particle Size:	0.35 in (8.9 mm)
Sound Pressure:	77 dB(A)
Operating temperature:	Determined by elastomers



### FT20 Performance

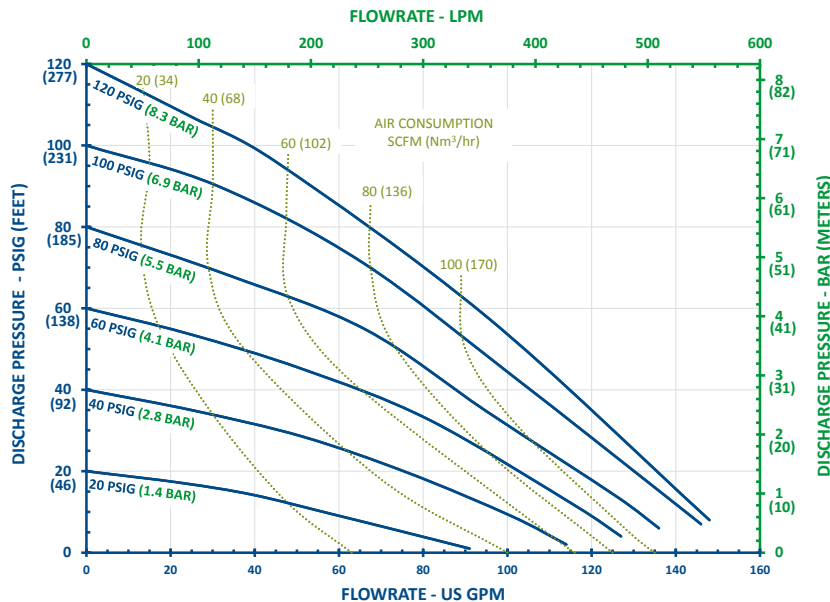

Note: Full stroke diaphragm allows performance to be equal for all elastomers.

### Typical Applications

- Acids & Bases
- Plating Solutions
- Wastewater
- Paints, Inks, Solvents
- Ceramic Slip and Glaze
- Lubricants and Oils

### Typical Industries

- Mining
- Paints and Coatings
- Ceramics
- Pulp and Paper
- Electroplating & Anodizing
- Wastewater
- Marine
- Chemical Manufacturing & Distribution
- OEM's

# CHANGE IS IN THE AIR

## Construction

Wetted Materials:	Aluminum
Diaphragm Materials:	Neoprene, Santoprene™, FKM, EPDM, PTFE, Buna, Hytrel®, Polyurethane
Air Valve:	GFRPP, Aluminum
Ball Materials:	Neoprene, Buna, EPDM, FKM, Santoprene™, PTFE, 316SS
Seat Materials:	Aluminum, 316SS, PTFE, Hytrel, Buna, Neoprene, EPDM, FKM, Santoprene™, Polyurethane
O-ring Materials:	Neoprene, Buna, EPDM, FKM, PTFE, FEP/FKM

Santoprene™ is a registered trademark of Exxon Mobil Corp.  
Hytrel® is a registered trademark of Dupont™

Pat. <http://ftiair.com/resources/ip/>

## Dimensions

Maximum Height:	28-7/8 in (733 mm)
Maximum Width:	20-7/8 in (530 mm)
Maximum Depth:	12-27/32 in (326 mm)

## Weight

Aluminum:	87 lb (39.5 kg)
-----------	-----------------

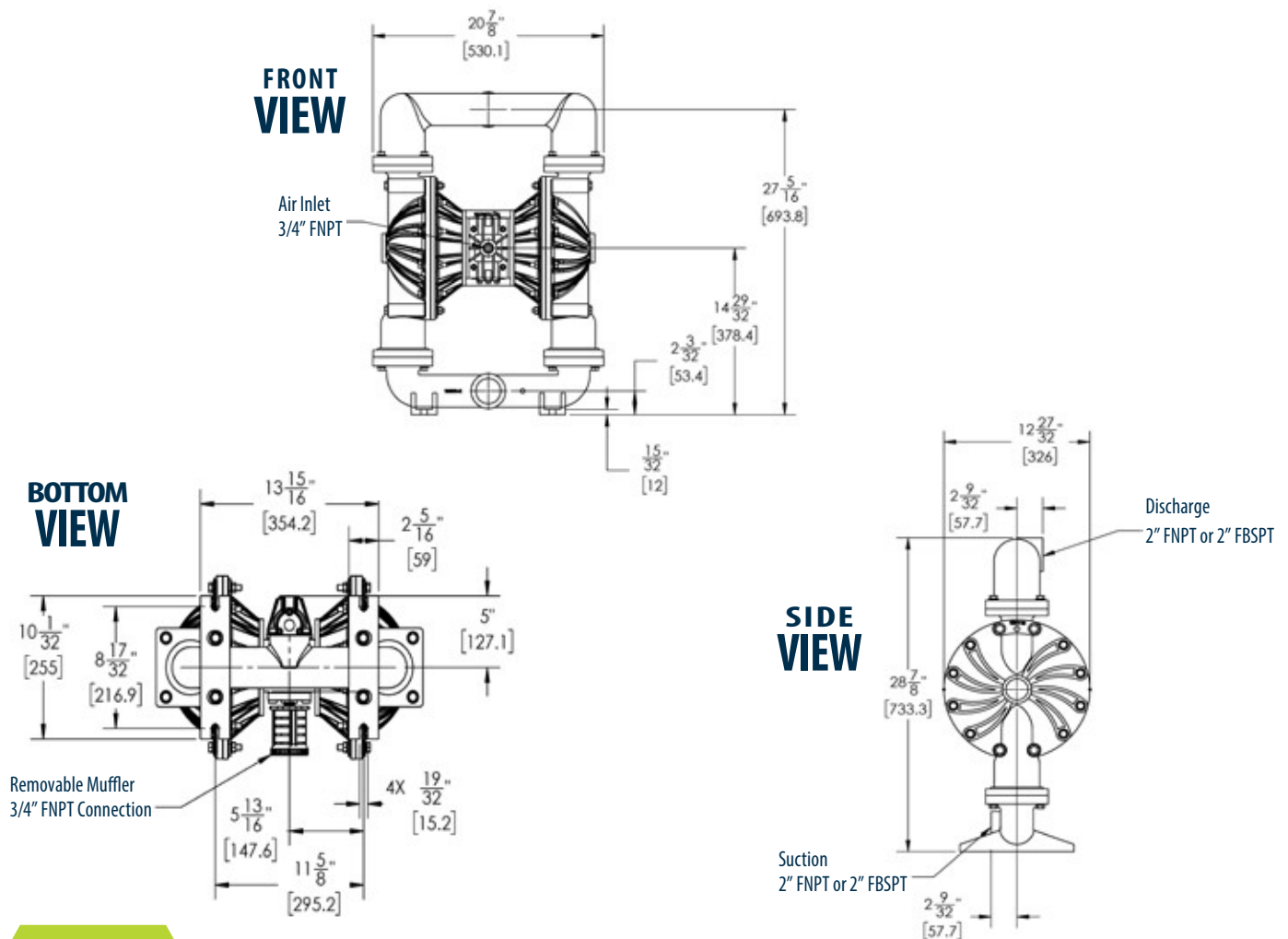

### FTI AIR

921 GREENGARDEN ROAD ERIE, PA 16501  
Tel: (800) 934-9384 • Fax: (814) 459-3460  
[www.FTIAIR.com](http://www.FTIAIR.com)

